



B.Tech IV Semester Regular/Supplementary Examinations, September 2023
Engineering Mechanics
(Electrical and Electronics Engineering)

Maximum Marks: 70

Duration: 3 hours

Part-A

All the following questions carry equal marks

(10x2M=20 Marks)

- 1 State the parallelogram law of forces.
- 2 Differentiate between a moment and a couple.
- 3 Give the laws of dry friction.
- 4 Define centroid of a plane area.
- 5 What is polar moment of inertia?
- 6 Write down the equation of moment of inertia about centroidal axes for a rectangle.
- 7 What is dynamic equilibrium?
- 8 Give the equation of work- energy for rectilinear motion.
- 9 What is forced vibration?
- 10 Give the principle of virtual work.

Part-B

Answer All the following questions.

(5X10M=50Marks)

- 11 Determine the X & Y components of each of the forces shown in Figure. Also find the resultant and the direction. [10]

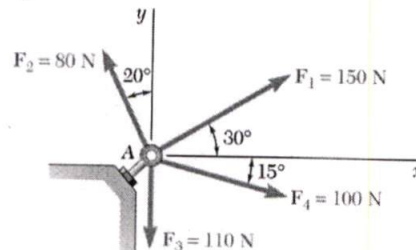

OR

- 12 A cord supported at A and B carries a load of 20 kN at D and a load of 'W' at C as shown in figure. Find the value of 'W' so that CD remains horizontal. [10]

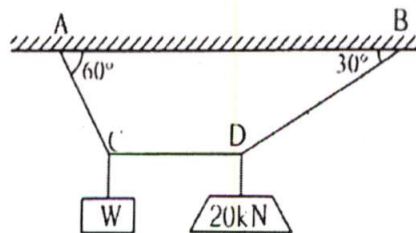

- 13 What horizontal force P must be applied to the weightless wedges B and C as shown in figure, to start them under the 500kg block A . The angle of friction for all contact surfaces is 15° . [10]

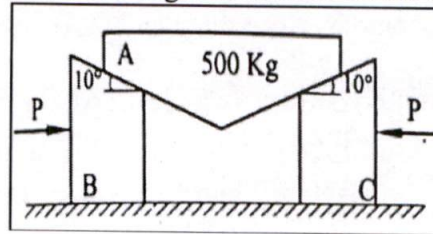

OR

- 14 A uniform lamina shown in figure consists of a rectangle, a circle and a triangle. Determine the centre of gravity of the lamina. [10]

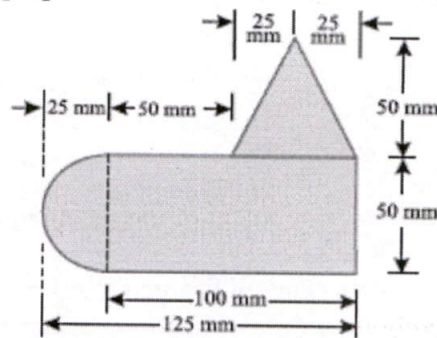

- 15 Determine the moment of inertia about the Centroidal axis of the L-section shown in figure. [10]

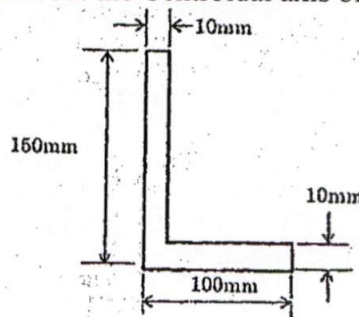

OR

- 16 Find the moment of inertia of circular plate of radius ' R ' and thickness ' t ' about its centroidal axes. [10]
- 17 Block P of weight 100 N and block Q of weight 50 N are connected by a rope that passes over a smooth pulley as shown in figure. Find the acceleration of the blocks and the tension in the rope, when the system is released from rest. Neglect the mass of the pulley. [10]

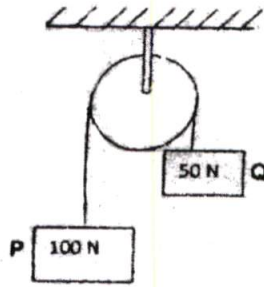

OR

- 18 A body weighing 300 N is pulled up on a 25° plane by force of 450 N acting parallel to the plane. If the initial velocity of the body is 1.1 m/sec and coefficient of friction is 0.18, what will be the velocity, after moving 4 m? [10]
- 19 Calculate the amplitude, angular frequency, frequency, time period and initial phase for the simple harmonic oscillation given below. [10]
- (i) $y = 0.3 \sin(40\pi t + 1.1)$
- (ii) $y = 2 \cos(\pi t)$
- (iii) $y = 3 \sin(2\pi t - 1.5)$

OR

- 20 Derive the time period for the compound pendulum. [10]

