



*R18 Regulation*  
**TKR COLLEGE OF ENGINEERING AND TECHNOLOGY**  
(Autonomous, Accredited by NAAC with 'A' Grade)

*Subject code: 2P5AA*

**B.Tech V Semester Supplementary Examinations, June 2022**  
**STRUCTURAL ANALYSIS-II**  
(CIVIL ENGINEERING)

**Maximum Marks: 70**

Date: 02.07.2022 Duration: 3 hours

- Note:**
1. This question paper contains two parts A and B.
  2. Part A is compulsory which carries 20 marks. Answer all questions in Part A.
  3. Part B consists of 5 Units. Answer any one full question from each unit.
  4. Each question carries 10 marks and may have a, b, c, d as sub questions.

**Part-A**

**All the following questions carry equal marks**

**(10x2M=20 Marks)**

- 1 Write formula for degree of Kinematic indeterminacy of trusses.
- 2 What is the formula for static Indeterminacy?
- 3 What is the maximum bending moment for simply supported beam with UDL 'W' kN/m acting on entire span of length L.
- 4 Write formula for horizontal thrust in two hinged arch.
- 5 Write the formula for Distribution factor in moment distribution method.
- 6 Fixed end moment for Point load placed eccentrically.
- 7 Write condition for Rotation factor in Kani's method.
- 8 What is the displacement we consider stiffness matrix method?
- 9 Write stiffness condition for continuous beam whose far end is hinged.
- 10 Draw three span continuous beam with udl, equally placed point load & eccentric placed point load on each span respectively?

**Part-B**

Answer All the following questions.

**(10M X 5=50Marks)**

- 11 Determine the vertical and horizontal displacement at the free end 'D' in the frame shown in fig. Take  $EI=12 \times 10^3 \text{ N-mm}^2$  Use Castigliano's theorem.

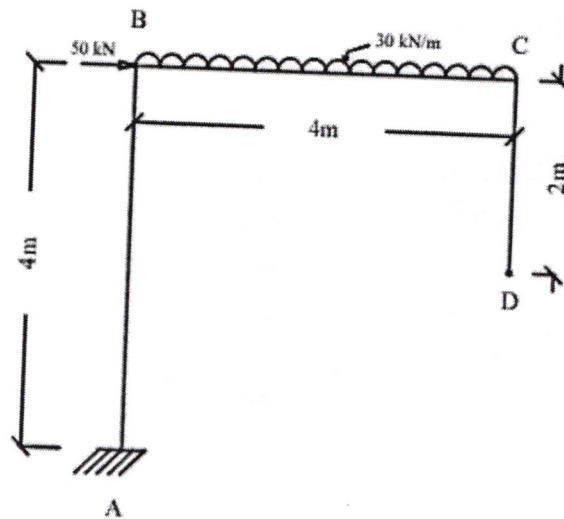

OR

- 12 A Two Hinged Parabolic Arch of length 'L' carries a UDL of 'W' kN/m over a length of L/2 from left support. Show that  $H = \frac{wl^2}{16h}$

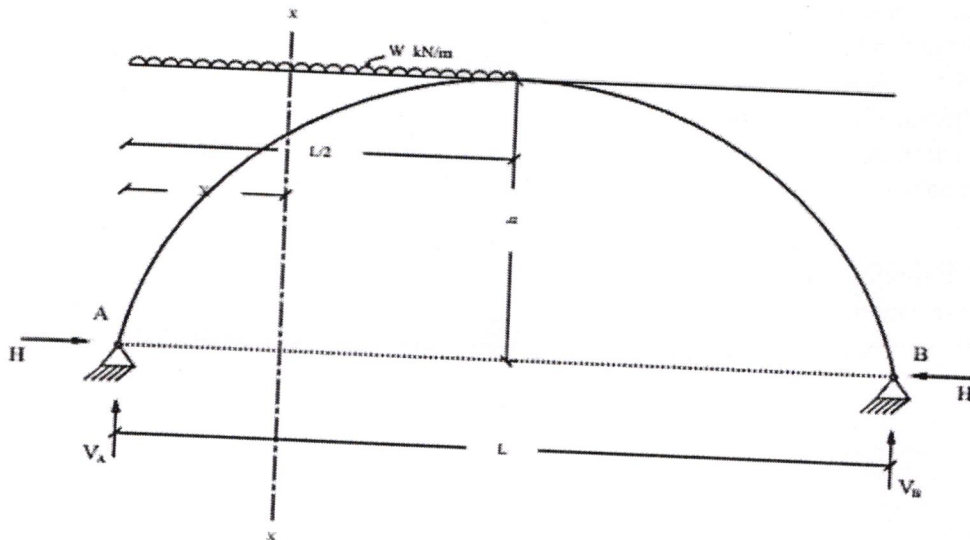

- 13 Consider a frame ABCD, the length of the members AB=5m, BC=4m and CD=5m, where span BC carries a point load of 15kN at 2m from joint B, while both the ends of the frame are fixed. Analyze the frame using slope deflection method.

OR

- 14 Using moment distribution method analyse the unsymmetrical frame and draw B.M.D

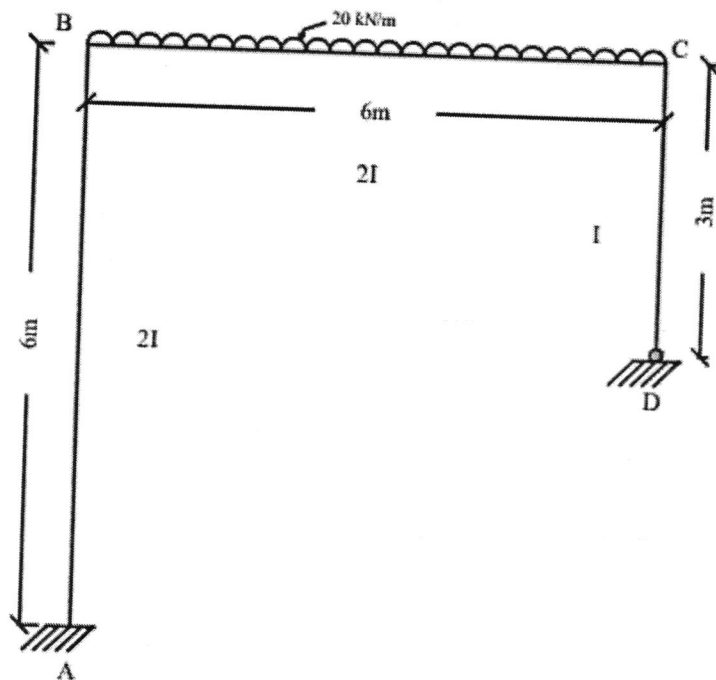

- 15 Analyse the continuous beam which is fixed at A & D as shown in fig. Apply kani's method to analyse the given beam.

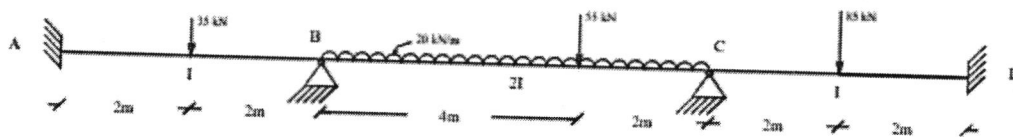

OR

- 16 Analyse the single bay-double storey frame carrying UDL as shown in fig. Apply kani's method on given frame.

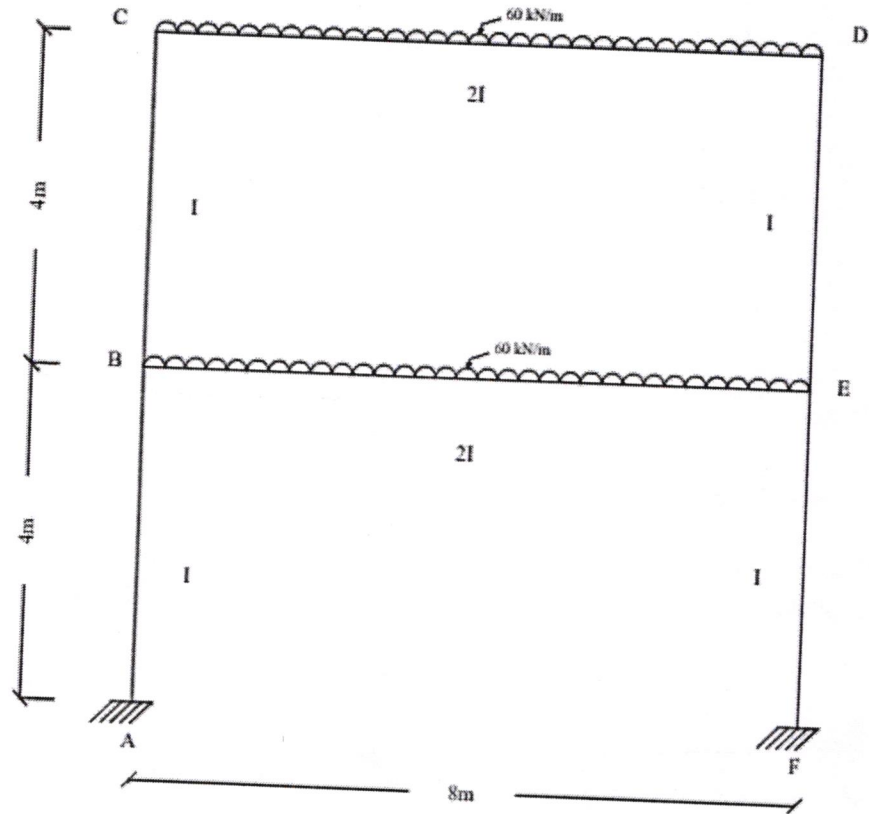

- 17 Using matrix method of analysis. Analyse the three span continuous beam which is fixed at supports A & D, hinged at B & C shown in figure.

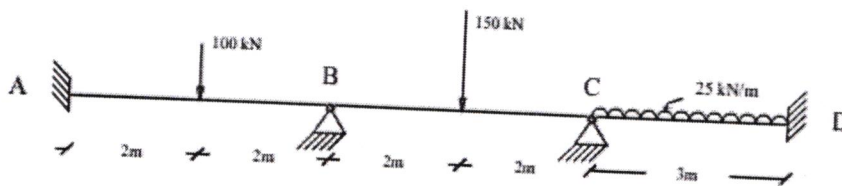

OR

- 18 Analyse the beam shown in figure by Stiffness matrix method.

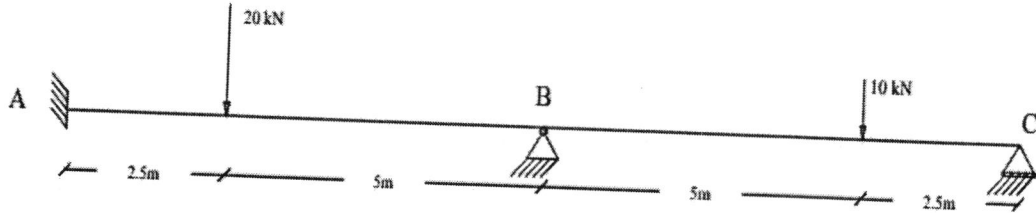

- 19 Apply the Approximate method of analysis on given multi-storey frame, using cantilever method.

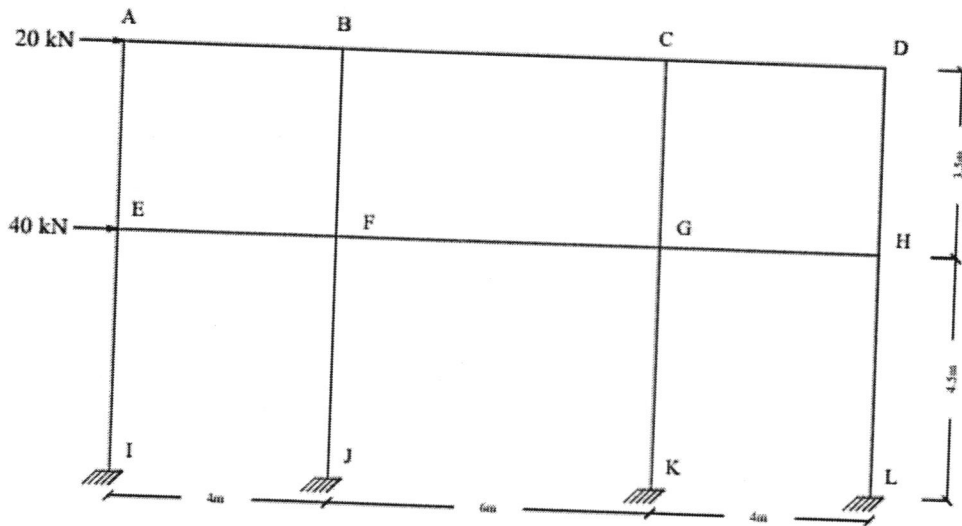

OR

20 Analyse the three bay-Double storey frame, Using Portal method.

