



R25 Regulation

Subject code:5ES1AN

**TKR COLLEGE OF ENGINEERING AND TECHNOLOGY**  
(Autonomous, Accredited by NAAC with 'A+' Grade)

**B.Tech I Semester Regular Examinations, January 2026**  
**BASIC ELECTRICAL ENGINEERING**  
(Common to CSE(DS) & IT)

Maximum Marks: 60

Date:23.01.2026

Duration: 3 hours

- Note: 1. This question paper contains two parts A and B.  
2. Part A is compulsory which carries 10 marks. Answer all questions in Part A.  
3. Part B consists of 5 Units. Answer any one full question from each unit.  
4. Each question carries 10 marks and may have a, b, c, d as sub questions.

Part-A

All the following questions carry equal marks (5X2M=10 Marks)		Marks	CO	BTL
1.a	Define superposition theorem.	2M	1	1
b	What is resonant frequency. Write the formula for resonant frequency	2M	2	2
c	List few properties of ideal transformer	2M	3	1
d	Write the advantages of three-phase induction motor	2M	4	2
e	What is battery. Give the classification of batteries	2M	5	2

Part-B

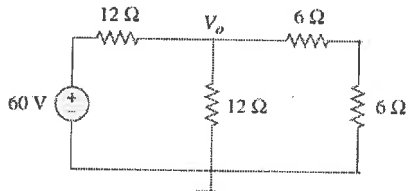
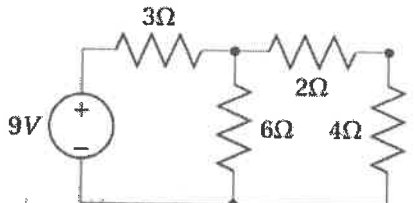
Answer All the following questions. (5X10M=50Marks)		Marks	CO	BTL
2	a) State and explain Kirchoff's laws b) Determine the current delivered by the 60V source in the circuit shown below 	5M 5M	1	2
OR				
3	a) State and explain Norton's theorem. b) Determine the current through 4Ω resistor using Thevenin's theorem 	5M 5M	1	2
4	a) Derive the expression current and voltage for series RL circuit. b) A sinusoidal voltage is represented by $v(t) = 325.27\sin(314t)$ .	5M	2	2

	Determine the maximum value, rms value, average value, angular velocity and frequency of the system.	5M		
	OR			
5	a) A series RL circuit has $R=20\Omega$ and $L=30\text{mH}$ . Determine: (i) Current (ii) Impedance (iii) Voltage across resistor b) Derive the relationship between phase and line quantities of voltage and current in a balanced star connection	5M    5M	2	2
6	a) Discuss the different types of losses in a transformer b) A single-phase 2200/250 V, 50Hz transformer has a flux of 21.6 mWb. Calculate the number of turns of primary and secondary.	5M 5M	3	2
	OR			
7	a) What is auto transformer. Discuss the advantages of auto transformer. b) What is regulation. Give the formula for regulation of transformer.	5M 5M	3	2
8	Explain the construction and working principle of DC generator with neat diagrams	10M	4	2
	OR			
9	a) Discuss the working principle of three-phase induction motor b) Explain the construction of synchronous generator.	5M 5M	4	2
10	What is MCB. Discuss its advantages over normal fuse. Explain its working under. (i) overloading conditions (ii) short circuit conditions	10M	5	2
	OR			
11	a) What is cable. How it is different from wire. Give the classification of cables. b) In a house, there are 5 lamps of 20 Watt used 12 hours per day and a 200-Watt refrigerator used 24 hours per day. How much electrical energy(kWh) is consumed in 30 days.	5M 5M	5	2