



R22 Regulation

Subject code:4E1DC

TKR COLLEGE OF ENGINEERING AND TECHNOLOGY

(Autonomous, Accredited by NAAC with 'A+' Grade)

B.Tech I Semester Supplementary Examinations, January 2026

COMPUTER AIDED ENGINEERING GRAPHICS

(IT)

Maximum Marks: 60

Date: 09.01.2026

Duration: 3 hours

- Note:
- 1.This question paper contains two parts A and B.
 2. Part A is compulsory which carries 20 marks. Answer all questions in Part A.
 3. Part B consists of 5 Units. Answer any one full question from each unit.
 4. Each question carries 10 marks and may have a, b, c, d as sub questions.

Part-A

All the following questions carry equal marks (10X1M=10 Marks)		Marks	CO	BTL
1.a	Define Eccentricity.	1M	1	L1
b	Define a Cycloid.	1M	1	L1
c	In IV quadrant, the front will be _____ the reference line.	1M	2	L1
d	Initial work and construction lines are drawn using _____ pencil.	1M	2	L1
e	Define a cone.	1M	3	L1
f	What is meant by prism?	1M	3	L1
g	When the surfaces of a solid are laid out on a plane, the figure obtained is called its.....	1M	4	L1
h	Every line on the development of surfaces must be the _____ of the corresponding edge on the surface.	1M	4	L1
i	A line is perpendicular to vertical plane. Its vertical trace coincides with its _____ view.	1M	5	L1
j	If a line has one of its ends in the vertical plane. Its vertical trace coincides with the _____	1M	5	L1

Part-B

Answer All the following questions. (5X10M=50Marks)		Marks	CO	BTL
2	Draw a cycloid of a circle of diameter 60mm for one revolution. Also draw a tangent and a normal to the curve at a point 35mm above the base line.	10M	1	L2
OR				
3	Construct a Parabola when the distance of the focus from the directrix is 50mm. Also draw a tangent and normal at point 70mm from the directrix.	10M	1	L2
4	A line AB 75mm long is inclined to HP at 30° and to VP at 45°. Draw its projections when one of the end is 20 above HP and 30 in front of VP.	10M	2	L2
OR				
5	A Pentagonal Plane of side 40mm is inclined to HP at 30° and its surface is inclined to VP at 45°. Draw its Projections draw its projections when one of the side is perpendicular to HP	10M	2	L2

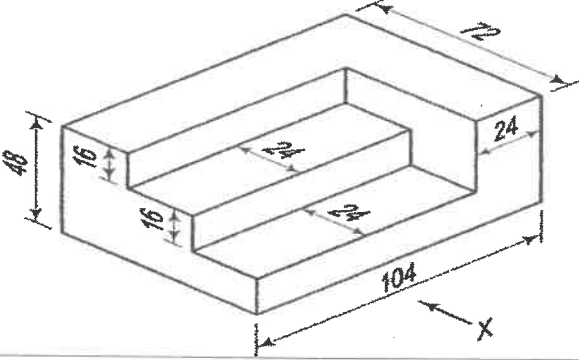
6	A Hexagonal pyramid of base side 30 mm and axis length 65 mm is inclined to H.P at 30° and its axis is inclined to V.P at 45° draw its projections.	10M	3	L2
OR				
7	A pentagonal prism of base side 30 mm and axis length 65 mm is inclined to H.P at 30° and its axis is inclined to V.P at 45° draw its projections.	10M	3	L2
8	A square pyramid of base side 25 mm and altitude 50 mm rests on its base on the HP with two sides of the base parallel to the VP. It is cut by a plane bisecting the axis and inclined at 30° to the base. Draw the development of the lateral surfaces of the lower part of the cut pyramid.	10M	4	L2
OR				
9	A hexagonal prism, edge of base 20 mm and axis 50 mm long, rests with its base on HP such that one of its rectangular faces is parallel to VP. It is cut by a plane perpendicular to VP, inclined at 45° to HP and passing through the right corner of the top face of the prism. Develop the lateral surface of the prism.	10M	4	L2
10	Draw the front view, top view and side view of the figures shown below. All dimensions are in mm	10M	5	L2
				
OR				
11	Draw an isometric diagram from given orthographic projection views shown in figures.	10M	5	L2
