



B. Tech II Semester Supplementary Examinations, January 2026

ENGINEERING GRAPHICS

(Common to EEE & ECE)

Maximum Marks: 70

Date: 24.01.2026

Duration: 3 hours

- Note:** 1. Consists of 10 questions. Answer any 5 questions
 2. Each question carries equal marks

All the following questions carry equal marks (14MX5=70 Marks)		Marks	CO	BTL
1	A circle of 40 mm diameter rolls on a straight line for Half revolution and for the remaining Half on vertical line draw the curve traced by a point P on circumference of the circle taking the top most point on the revolving circle as the initial position of the generating point.	14M	1	L1
OR				
2	A Fixed point is at a distance of 50mm from fixed straight line trace the path of the curve if $e = 3/2$. Draw tangent and normal to it at a dist. of 40mm from directrix.	14M	1	L1
3	The Front view and Top view of a straight-line PQ measures 50mm and 65mm respectively. the point P is in the HP and 20mm in front of VP, and the front view of the line is inclined at 45° to XY. Determine the true length and true angle.	14M	2	L1
OR				
4	Draw the projections of a circular plane with a 50mm diameter, resting on a point A on its circumference in the HP such that its surface is inclined at 30° to VP and inclined to HP at 45° draw its projections.	14M	2	L1
5	A pentagonal pyramid of base side 30mm axis length 65 mm is inclined to HP at 45° Draw its Projections	14M	3	L1
OR				
6	A Hexagonal Plane of side 30mm is inclined to HP at 30° and its surface is inclined to VP at 45° . Draw its Projections when one of the side is perpendicular to HP.	14M	3	L1
7	A Pentagonal Pyramid of side 30mm axis length 70mm has its axis inclined to HP at 30° and its edge inclined to VP at 45° . Draw its projections.	14M	4	L1
OR				

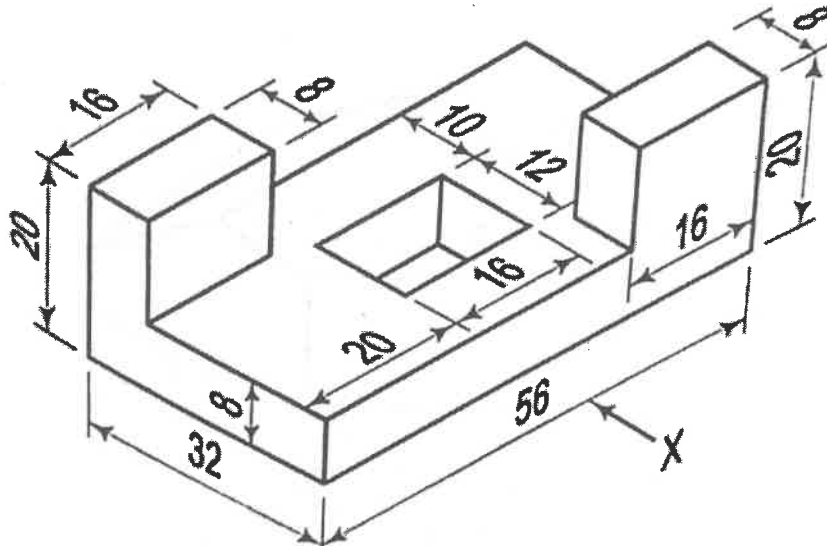
8	Draw the development of a cone of diameter 40mm axis length 65mm is sectioned by a plane inclined at 35° to HP and passing through midpoint of the axis of the cone.	14M	4	L1
9	A Cone is placed centrally on the top of a cube with 40mm side which is placed centrally over a cylindrical block. The cone has base diameter 30mm and axis length 40mm. The cylindrical block has 80mm base diameter and 10mm thickness. Draw the isometric projection.	14M	5	L1
OR				
10	<p>Draw front View top vies and side view for the following figure:</p> 	14M	5	L1