



B.Tech I Semester Supplementary Examinations, June 2024

COMPUTER AIDED ENGINEERING GRAPHICS

(Common to EEE, CSE & CSE(AI&ML))

sMaximum Marks: 60

Date:05.07.2024 Duration: 3 hours

- Note:**
1. This question paper contains two parts A and B.
 2. Part A is compulsory which carries 10 marks. Answer all questions in Part A.
 3. Part B consists of 5 Units. Answer any one full question from each unit.
 4. Each question carries 10 marks and may have a, b, c, d as sub questions.

Part-A

All the following questions carry equal marks		(10X1M=10 Marks)	CO	Bloom Tx
1.	a	Define Eccentricity.	1	1
	b	Define a Cycloid.	1	2
	c	Centre lines, section lines are drawn using _____ pencil	2	2
	d	Name the Principal Plane of Projections?	2	1
	e	Give the symbolic representation of first and third angle projection	3	1
	f	Define an auxiliary inclined plane.	3	1
	g	Applications of development of surface	4	1
	h	Name the types of solids.	4	1
	i	When the projectors are parallel to each other and also perpendicular to the plane, the projection is called	5	1
	j	In orthographic projection each projection view represents how many dimensions of an object _____	5	1

Part-B

Answer All the following questions.		(10MX 5=50Marks)		
2		Construct a scale of 1:40 to read meters, decimeters and centimeters and long enough to measure up to 6m. Mark a distance of 4.76m on it. [10M]	1	3
OR				
3		Draw an ellipse when the distance of its focus from its directrix is 50mm and eccentricity is 2/3. Also draw a tangent and a normal to the ellipse at a point 70mm away from the directrix. [10M]	1	3
4		A circle of diameter 50 mm inclined at 30° to HP and perpendicular to VP, has its center 30 mm in front of VP. Draw the projection of lamina and side view. [10M]	2	3
OR				
5		A line AB 70 mm long is inclined at an angle of 40° to the H.P. and 30° to the V.P. The end A is in V.P and 30 mm above H.P. Draw the projections of the line. [10M]	2	3
6		A square prism of base edge 35 mm and axis 60 mm is resting on an edge of its base on the H.P. and the axis inclined at 45° to the H.P. If the edge resting on the H.P. is inclined at 30° to the V.P., draw its projections. [10M]	3	3

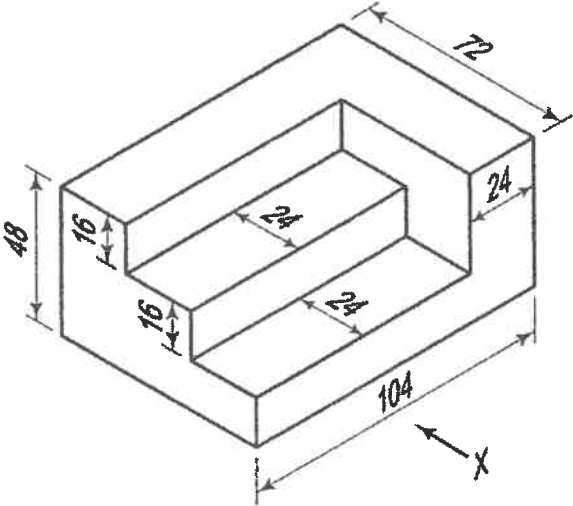
	OR		
7	A cylinder of base diameter 30 mm and axis length 60 mm is inclined to H.P at 30° and its axis is inclined to V.P at 45° . Draw its projections. [10M]		3
8	A pentagonal prism, having a base 30mm side and 70mm long axis is resting on its base on H.P such that one of its rectangular surfaces is parallel to V.P. It is cut by an auxiliary inclined plane at 45° and passes through the midpoint of the axis. Draw the developments of truncated prism. [10M]		3
	OR		
9	A hexagonal prism, side of base 25 mm and altitude 50 mm, rests on its base on the HP such that an edge of the base is parallel to VP and nearer to the observer. It is cut by a plane inclined at 30° to HP, perpendicular to VP and passing through the centre of the axis. Draw the development of the complete surfaces of the truncated prism. [10M]		3
10	Draw the front view, top view and side view of the figures shown below. All dimensions are in mm. [10M]	5	3
			
	OR		
11	Draw an isometric diagram from given orthographic projection views shown in figures. [10M]	5	3
