



R22 Regulation

Subject Code:4E1DD

TKR COLLEGE OF ENGINEERING AND TECHNOLOGY

(Autonomous, Accredited by NAAC with 'A' Grade)

B.Tech I Semester Supplementary Examinations, September 2023

Computer Aided Engineering Graphics

(CSE(AI&ML))

Maximum Marks: 60

Date:05.10.2023 Duration: 3 Hours

- Note:
1. This question paper contains two parts A and B.
 2. Part A is compulsory which carries 10 marks. Answer all questions in Part A.
 3. Part B consists of 5 Units. Answer any one full question from each unit.
 4. Each question carries 10 marks and may have a, b, c, d as sub questions.

Part-A

All the following questions carry equal marks

(10x1M=10 Marks)

- 1 Define Eccentricity
- 2 Define a Cycloid
- 3 Initial work and construction lines are drawn using _____ pencil.
- 4 In II quadrant, the front view will be _____ the reference line..
- 5 What is meant by pyramid
- 6 Define a cone
- 7 When the surfaces of a solid are laid out on a plane, the figure obtained is called its _____
- 8 Every line on the development of surfaces must be the _____ of the corresponding edge on the surface
- 9 When the projectors are parallel to each other and also perpendicular to the plane, the projection is called _____
- 10 In orthographic projection each projection view represents how many dimensions of an object _____

Part-B

Answer All the following questions.

(10MX 5=50Marks)

- 11 Construct a scale of 1:40 to read metres, decimetres and centimetres and long enough to measure up to 6m. Mark a distance of 4.76m on it. [10]
OR
- 12 Draw an ellipse when the distance of its focus from its directrix is 50mm and eccentricity is $\frac{2}{3}$. Also draw a tangent and a normal to the ellipse at a point 70mm away from the directrix. [10]
- 13 Draw the projections for the following points keeping the distance between the projectors as 25mm on the same reference line. [10]
A point on HP and 30mm in front of VP B 50mm below HP 30mm behind VP
C 35mm below HP on VP D 50mm below HP 20mm in front of VP
E on HP 30mm above 50mm behind VP
OR
- 14 Draw the projections of a circular plane with a 50mm diameter, resting on a point A on its circumference in the HP such that its surface is inclined at 30° to HP, draw its projections. [10]

- 15 A Hexagonal pyramid of base side 30 mm and axis length 65 mm is inclined to H.P at 30° and its axis is inclined to V.P at 45° draw its projections. [10]
OR
- 16 A cylinder of base diameter 30 mm and axis length 60 mm is inclined to H.P at 30° and its axis is inclined to V.P at 45° . Draw its projections. [10]
- 17 A pentagonal prism, having a base 30mm side and 70mm long axis is resting on its base on H.P such that one of its rectangular surfaces is parallel to V.P. It is cut by an auxiliary inclined plane at 45° and passes through the midpoint of the axis. Draw the developments of truncated prism. [10]
OR
- 18 Draw the development of lateral surface of hexagonal pyramid with a 30mm base side and 60mm long axis, which is resting on its base in the H.P such that an edge of the base is perpendicular to V.P when a horizontal section plane cuts the pyramid at a height of 25mm from the base. [10]
- 19 Draw the front view, top view and side view of the figures shown below. All dimensions are in mm. [10]

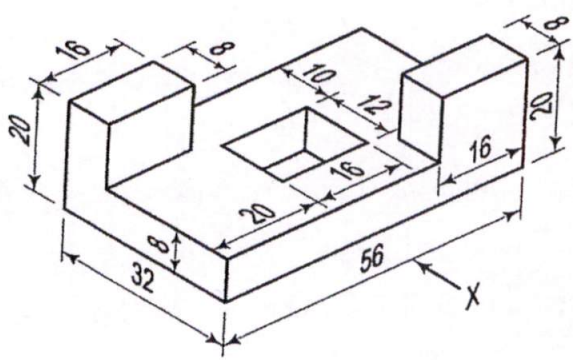

- 20 Draw an isometric diagram from given orthographic projection views shown in figures. [10]

