



R22 Regulation

Subject Code:4E1DC

TKR COLLEGE OF ENGINEERING AND TECHNOLOGY

(Autonomous, Accredited by NAAC with 'A' Grade)

B.Tech I Semester Supplementary Examinations, September 2023

Computer Aided Engineering Graphics (IT)

Maximum Marks: 60

Date:30.09.2023 Duration: 3 Hours

- Note:
1. This question paper contains two parts A and B.
 2. Part A is compulsory which carries 10 marks. Answer all questions in Part A.
 3. Part B consists of 5 Units. Answer any one full question from each unit.
 4. Each question carries 10 marks and may have a, b, c, d as sub questions.

Part-A

All the following questions carry equal marks

(10x1M=10 Marks)

- 1.a Mention the different types of scales used in practice
- b Define the conic sections
- c Centre lines, section lines are drawn using _____ pencil
- d In IV quadrant, the front will be _____ the reference line.
- e What is meant by prism
- f What is meant by solid
- g Applications of development of surface _____
- h The form of sheet obtained by laying all outer surfaces of solid with suitable allowances for the joints is known as _____
- i Orthographic projection is the representation of _____ views on the mutual perpendicular projection planes.
- j A line AB is on the horizontal plane inclined to vertical plane at 45 degrees, _____ view gives the actual length of the line AB.

Part-B

Answer All the following questions.

(10MX 5=50Marks)

- 2 Draw a Hyperbola when the distance of its focus from its directrix is 50mm and eccentricity is $3/2$. Also draw a tangent and a normal to the hyperbola at a point 25mm from the directrix. [10]
OR
- 3 Draw a cycloid of a circle of diameter 60mm for one revolution. Also draw a tangent and a normal to the curve at a point 35mm above the base line. [10]
- 4 A Pentagonal Plane of side 40mm is inclined to HP at 30° and its surface is inclined to VP at 45° . Draw its Projections when one of the side is perpendicular to HP. [10]
OR
- 5 A line AB 75mm long is inclined to HP at 30° and to VP at 45° . Draw its projections when one of the end is 20 above HP and 30 in front of VP. [10]
- 6 A pentagonal prism of base side 30 mm and axis length 65 mm is inclined to H.P at 30° and its axis is inclined to V.P at 45° draw its projections. [10]
OR

7 A cylinder of base diameter 50mm and height 65mm rests on its base on HP. It is cut by a plane perpendicular to VP and inclined at 30° to HP and meets the axis at a distance 30mm from the base. Draw the front view, sectional top view. [10]

8 A hexagonal prism, edge of base 20 mm and axis 50 mm long, rests with its base on HP such that one of its rectangular faces is parallel to VP. It is cut by a plane perpendicular to VP, inclined at 45° to HP and passing through the right corner of the top face of the prism. Develop the lateral surface of the prism. [10]

OR

9 A hexagonal prism, side of base 25 mm and altitude 50 mm, rests on its base on the HP such that an edge of the base is parallel to VP and nearer to the observer. It is cut by a plane inclined at 30° to HP, perpendicular to VP and passing through the centre of the axis. Draw the development of the complete surfaces of the truncated prism. [10]

10 Draw the front view, top view and side view of the figures shown below. All dimensions are in mm. [10]

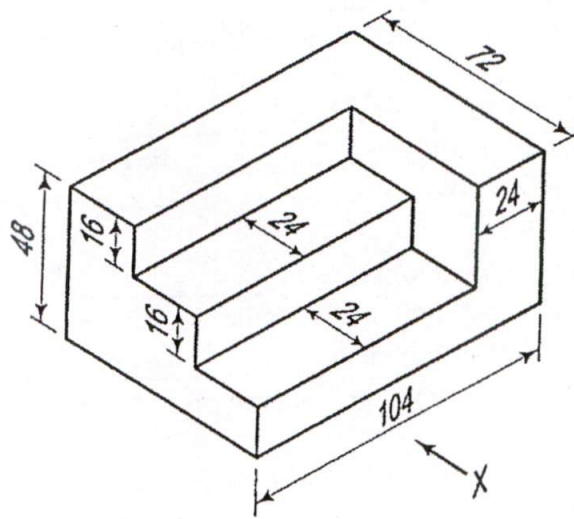

OR

11. Draw an isometric diagram from given orthographic projection views shown in figures.

[10]

