



R20 Regulation

TKR COLLEGE OF ENGINEERING AND TECHNOLOGY

(Autonomous, Accredited by NAAC with 'A' Grade)

Subject code: 3E2AQ

**B.Tech II Semester Regular/Supplementary Examinations, October 2022**  
**ENGINEERING GRAPHICS**

(ECE)

Maximum Marks: 70

Date:20.10.2022 Duration: 3 hours

- Note: 1. It consists of 5 Units. Answer any one full question from each unit which carries 14M.  
2. Each question carries 14 marks and may have a, b, c, d as sub questions.

Answer All the following questions.

(14MX 5=70Marks)

- 1 Construct an ellipse when the distance of the focus from the directrix is equal to 50mm and eccentricity is  $2/3$ . [14M]  
OR
- 2 A circle of 50mm diameter rolls along a straight line without slipping. Draw the curve traced out by a point  $p$  on the circumference, for one complete revolution of the circle. Name the curve. Draw tangent to the curve at a point on it 40mm from the line. [14M]
- 3 (A) A point  $p$  is 50mm from both the reference planes. Draw its projections in all possible positions. [7M]  
(B) The top view of a 75mm long line AB measures 65mm, while the length of its front view is 50mm. Its one end A is in the H.P and 12mm in front of the V.P. Draw the projections of AB and determine its inclinations with H.P and the V.P. [7M]  
OR
- 4 Draw the projections of a regular hexagon of 25mm side, having one of its sides in the H.P and inclined at  $60^\circ$  to the V.P, and its surface making an angle of  $45^\circ$  with the H.P. [14M]
- 5 A hexagonal pyramid, base 25mm side and axis 55mm long, has one of its slant edges on the ground. A plane containing that edge and the axis is perpendicular to the H.P and inclined at  $45^\circ$  to the V.P. Draw its projections when the apex is nearer the V.P than the base. [14M]  
OR
- 6 A square prism with side of its base 40mm and axis 70mm long is lying on one of its base edges on the H.P in such a way that this base edge makes an angle of  $45^\circ$  with the V.P and the axis is inclined at  $30^\circ$  to the H.P. Draw the projections of solid. [14M]
- 7 A cylinder of 40mm diameter, 60mm height and having its axis vertical, is cut by a section plane, perpendicular to the V.P, inclined at  $45^\circ$  to the H.P and intersecting the axis 32mm above the base. Draw its front view, sectional top view, sectional side view. [14M]  
OR
- 8 Draw the development of the frustum of a hexagonal pyramid of side of base 35mm at bottom and 15 mm at the top; the height of the frustum being 50mm. [14M]

- 9 Draw the front view, top view and side view of the figure shown below. All dimensions are in mm. [14M]

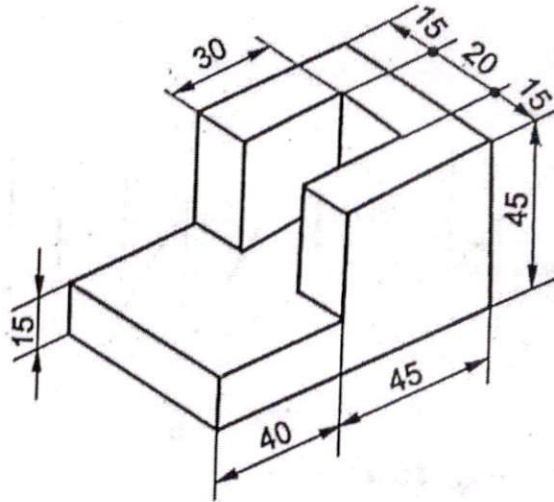

OR

- 10 Projection of a casting is given in the figure below. Draw the isometric view. [14M]

