



R17 Regulation

TKR COLLEGE OF ENGINEERING AND TECHNOLOGY
(Autonomous, Accredited by NAAC with 'A' Grade)

Subject code: 1E2AJ

B.Tech I Year II Semester Supplementary Examinations, October 2022

Engineering Graphics

(Common to EEE, ECE, CSE & IT)

Maximum Marks: 70

Date: 20.10.2022 Duration: 3 hours

- Note: 1. It consists of 5 Units. Answer any one full question from each unit which carries 14M.
2. Each question carries 14 marks and may have a, b, c, d as sub questions.

Answer All the following questions.

(14M X 5 = 70 Marks)

- 1 Draw a diagonal scale of RF = 3/100, showing meters, decimeters and centimeters and to measure up to 5 meters. Show the length of 3.69 meters on it. [14M]
OR
- 2 Draw a parabola having conjugate axes of 60 mm and 40 mm long and inclined at 75° to each other. [14M]
- 3 Draw the front view and top view of a square lamina. The surface of the lamina is inclined at 45° to HP and perpendicular to VP. [14M]
OR
- 4 A regular hexagonal plate of 40 mm side is inclined at 60° to HP and 30° to VP. Draw the projections of the plate if the thickness is negligible. [14M]
- 5 A hexagonal pyramid, having a base of 30 mm side and a 60 mm long axis, has an edge of its base on the ground and the axis is inclined at 30° to the HP. The edge of the base on which it rests is inclined 45° to the VP. Draw its projections. [14M]
OR
- 6 Draw the projections of a cone, base 45 mm diameter and axis 50 mm long, when it is resting on the ground on a point on its base circle with the axis making an angle of 30° with the HP and 45° with the VP. [14M]
- 7 A cone, with a 60 mm base diameter and a 70 mm long axis, is resting on its base on the HP. It is cut by an AIP bisecting the axis and is making 45° with the HP. Draw its sectional top view and true shape of the section. [14M]
OR
- 8 A hexagonal prism of base side 30 mm and height 70 mm, is resting on its base on the HP with a side of the base perpendicular to the VP. The prism has a cylindrical hole of diameter 40 mm, drilled centrally such that the axis of hole is perpendicular to the VP. Draw the development of the internal surface of the prism. [14M]

- 9 Draw the orthographic view of the following figure. All dimensions are in mm. [14M]

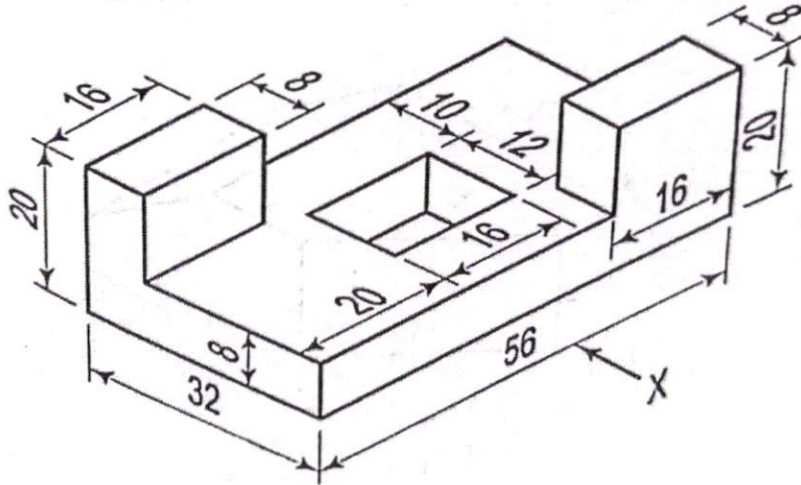

OR

- 10 Draw the isometric view of the following figure. All dimensions are in mm. [14M]

