



B.Tech III Year II Semester Supplementary Examinations, June 2022
FINITE ELEMENT METHODS

(Mechanical Engineering)

Maximum Marks: 70

Date: 21.06.2022 Duration: 3 hours

- Note:
1. This question paper contains two parts A and B.
 2. Part A is compulsory which carries 20 marks. Answer all questions in Part A.
 3. Part B consists of 5 Units. Answer any one full question from each unit.
 4. Each question carries 10 marks and may have a, b, c, d as sub questions.

Part-A

All the following questions carry equal marks

(10x2M=20 Marks)

- 1 What are the boundary conditions imposed for 1 Dimensional bar element.
- 2 Write global stiffness matrix for a bar element.
- 3 List the properties of the shape functions.
- 4 How local and global coordinates are related in a truss problem.
- 5 Write the hermite shape function of a beam element
- 6 What are the properties of a triangular coordinates.
- 7 Write the strain displacement equation of axisymmetric problems using a cylindrical coordinate system.
- 8 Write governing differential equation for two dimensional heat transfer problem
- 9 Differentiate lumped and consistent mass matrix.
- 10 List one requirement which is sufficient for convergence for a plate element.

Part-B

Answer All the following questions.

(5X10M=50Marks)

- 11 Derive the stress strain relation for a plane stress condition starting from Hook's law.(10)

OR

- 12 Determine the nodal displacements for two rails separated by a gap of 0.5 mm shown in the figure $P = 100\text{KN}$ $E = 80 \times 10^3 \text{ MPa}$ (10)

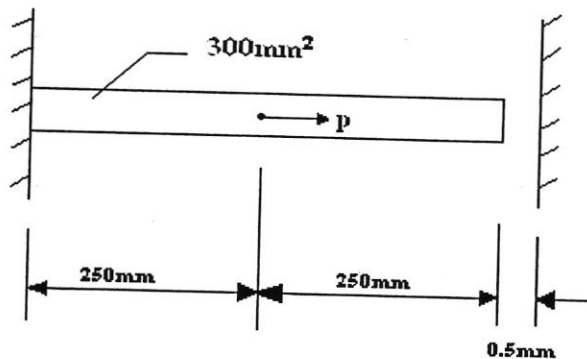

- 13 Calculate the nodal displacements and element stresses for the truss shown in the figure
 $E = 70 \text{ GPa}$, $A = 2 \text{ cm}^2$ for all truss members. (10)

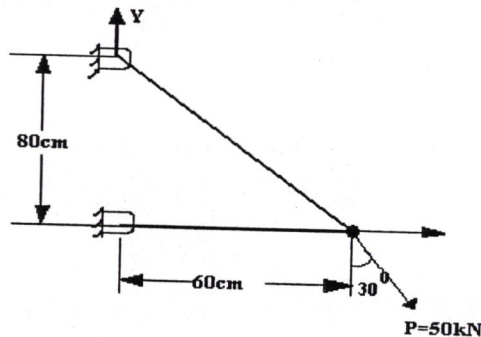

OR

- 14 Explain Hermite shape functions in detail. (10)
- 15 The (x, y) coordinates of nodes i, j and k of a triangular element are $(1, 1)$, $(6, 2)$ and $(4, 5)$ respectively. The shape functions of a point P located inside the element are given by $N_1 = 0.12$ and $N_2 = 0.35$. Determine x and y coordinates of point P . (10)

OR

- 16 Derive the jacobian matrix of a four noded quadrilateral element. (10)
- 17 Estimate the temperature distribution in 1-D fin as shown in the figure by making the fin into two elements. (10)

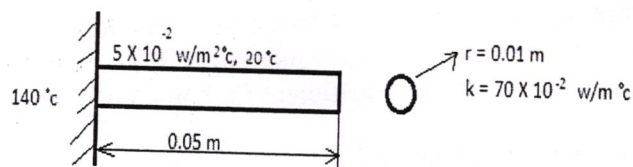

OR

- 18 (a) Write the governing equation for the torsional analysis of non-circular shaft. (5)
 (b) Write the application for the finite element analysis for thermal problems. (5)
- 19 Find the natural frequency of simply supported beam of length 800 mm, cross sectional area $75 \times 25 \text{ cm}$. $E = 200 \text{ GPa}$, $\rho = 7850 \text{ kg/m}$ (10)

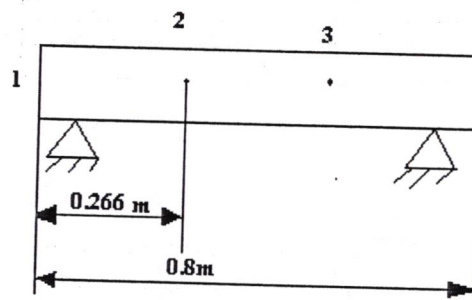

- OR
- 20 Consider axial vibrations of the steel stepped bar as shown in the below figure
(a) Develop global stiffness matrix and mass matrix (b) Find Natural Frequencies (10)

