



R17 Regulation

TKR COLLEGE OF ENGINEERING AND TECHNOLOGY
(Autonomous, Accredited by NAAC with 'A' Grade)

Subject code: 1P3AC

B.Tech II Year I Semester Supplementary Examinations, February 2021

FLUID MECHANICS-I

(CIVIL ENGINEERING)

Maximum Marks: 70

Date: 24.02.2021 Duration: 3 hours

- Note:
1. This question paper contains two parts A and B.
 2. Part A is compulsory which carries 20 marks. Answer all questions in Part A.
 3. Part B consists of 5 Units. Answer any one full question from each unit.
 4. Each question carries 10 marks and may have a, b, c, d as sub questions.

Part-A

All the following questions carry equal marks

(10x2M=20 Marks)

- 1 Define dynamic viscosity.
- 2 Define Vapour Pressure.
- 3 Define Rotational and Irrotational flow.
- 4 What is flow net in fluid flow?
- 5 List the instruments works on the basis of Bernoulli's equation.
- 6 Define Impulse Momentum Equation (or) Momentum Equation.
- 7 Define the terms a) Hydraulic gradient line [HGL] b) Total Energy line [TEL]
- 8 What is the expression for head loss due to friction?
- 9 Define transition zone.
- 10 What is flow separation in BL?

Part-B

Answer All the following questions.

(10M X 5=50Marks)

- 11 A rectangular plate of size 25 cm by 50 cm and weighing 25 kg(f) slides down a 30° inclined surface at a uniform velocity of 2 m/sec. If the uniform 2 mm gap between the plate and the inclined surface is filled with oil determine the viscosity of the oil. (10M)

OR

- 12 a) Two pipes as shown in Figure convey toluene of specific gravity 0.875 and water respectively. Both the liquids in the pipes are under pressure. The pipes are connected to a U-tube manometer and the hoses connecting the pipes to the tubes are filled with the corresponding liquids. Find the difference of pressure in two pipes if the level of manometric liquid having a specific gravity 1.25 is 2.25 m higher in the right limb than the lower level of toluene in the left limb of the manometer. (10M)

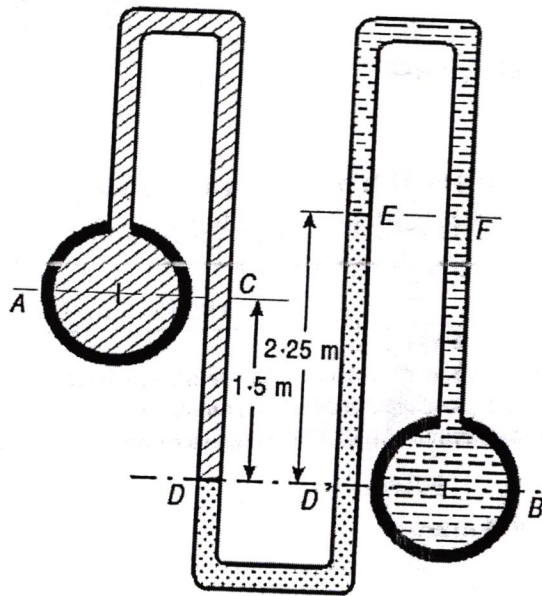

- 13 For the following stream functions, determine the potential function (10M)
 (i) $\psi = (3/2)(x^2 - y^2)$ (ii) $\psi = -8xy$ (iii) $\psi = x - y$
 OR
- 14 Distinguish between (i) steady flow and un-steady flow (ii) uniform and non-uniform flow and (iii) compressible and incompressible flow. (10M)
- 15 What are the assumption made for Bernoulli's equation and Derive the Bernoulli's equation from Euler's equation of motion. (10M)
 OR
- 16 a) A venturimeter as shown in figure is used measure flow of petrol with a specific gravity of 0.8. The manometer reads 10 cm of mercury of specific gravity 13.6. Determine the flow rate.(5M)

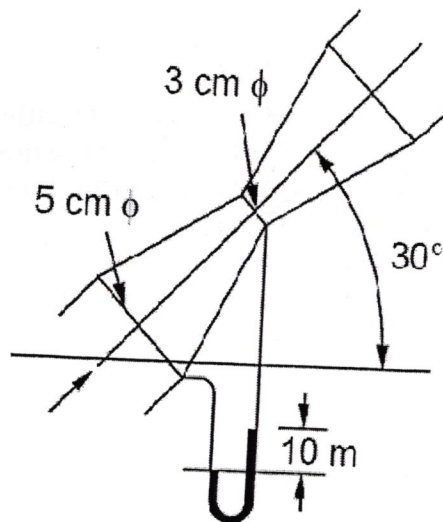

b) Water flows at the rate of $0.147 \text{ m}^3/\text{s}$ through a 150 mm diameter orifice inserted in a 300 mm diameter pipe. If the pressure gages fitted upstream and downstream of the orifice plate have shown readings of 176.58 kN/m^2 and 88.29 kN/m^2 respectively, find the coefficient of discharge C of the orifice meter. (5M)

17 Two pipes each 300 m long are available for connecting to a reservoir from which a flow of $0.085 \text{ m}^3/\text{s}$ is required. If the diameters of the two pipes are 0.30 m and 0.15 m respectively, determine the ratio of the head lost when the pipes are connected in series to the head lost when they are connected in parallel. Neglect minor losses. (10M)

OR

18 What are the different types of energy loss in flowing fluids? Derive the Darcy-Weisbach equation to determine the loss of head due to friction in pipes. (10M)

19 Assuming the velocity distribution in the boundary layer as $\frac{u}{u_\infty} = \sin\left(\frac{\pi y}{2\delta}\right)$ (in the range $0 \leq y \leq \delta$, and $u/u_\infty = 1$ beyond δ), determine the thickness of the boundary layer, using integral momentum method. (10M)

OR

20 Air flows over a flat plate 1 m long at a velocity of 6 m/s. Determine (a) the boundary layer thickness at the end of the plate, (b) shear stress at the middle of the plate, (c) total drag per unit length on the sides of the plate. Take $\rho = 1.226 \text{ kg/m}^3$ and $\nu = 0.15 \times 10^{-4} \text{ m}^2/\text{s}$ for air. (10M)

